

Hitachi Cable, Ltd

“RBT” Cable for Industrial machinery

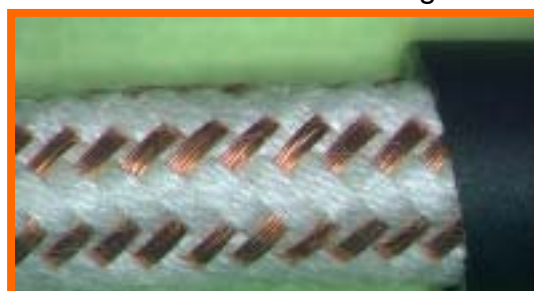

<Interweave braid shielding>



<Special wound conductor >



Engineering Dept.
Electronic Wires & Cables
Production Div.

Hitachi Cable, Ltd.

This data is lined up our cable for industrial machinery.

<< **Table of Contents** >>

No	Use	Rating voltage	No. of cond.	Size	P/N	Page
1	Flexure part	The feature of HITACHI "RBT" cables				1
2		60 V	2 ~ 20 pairs 2 ~ 20 cond.	0.14 ~ 0.56mm ²	RBT 1-V(SB) RBT 1-V	2
3		60 V	2 ~ 20 pairs 2 ~ 20 cond.	0.2 ~ 0.3mm ²	RBT 2-V(SB) RBT 2-V	3
4		600 V	2 ~ 20 cond.	0.5 ~ 2mm ²		4
5		600 V	2 ~ 20 pairs	0.5 ~ 1.25mm ²		5
6	Core identification					6
7	Expectation of flex life					7
8	Current carrying capacity					8

The feature of "HITACHI RBT" for high flexure part

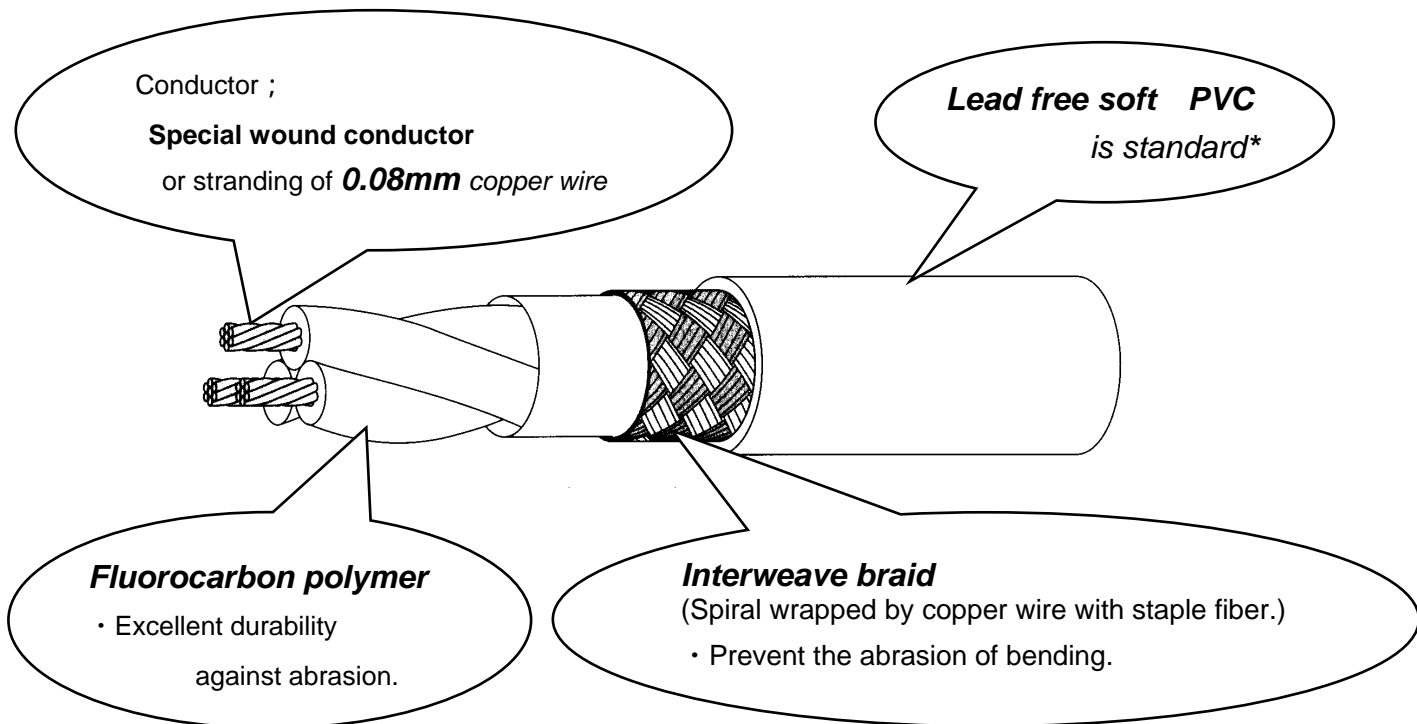

*Heat resistant and oil resistant PVC, Polyurethane, and Fluonlex(150 rated soft fluoro-ruber) are available.

“RBT 2-V” for flexure part

RBT 2-V(SB)

RBT 2-V

Rating : 60 , 60V

Hitachi Specification : SP31-91133B, SP31-91113B for multi pair type
 SP31-91134B, SP31-91114B for multi core type

Size variation

Size (mm ²)	Conductor		Ins. dia. (mm)	Max. cond. resistance (/km)
	Stranding (No./mm)	Dia. (mm)		
0.2	40/0.08	0.6	0.9	104
0.3	60/0.08	0.7	1.0	69.5

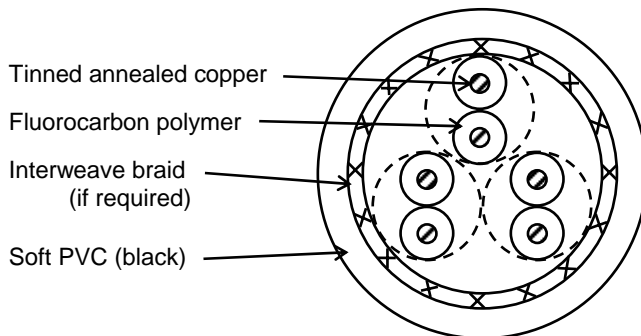

Overall Dia. 【Multi pair with and without shielding type】/(Approx. mass) unit : mm , (kg/km)

Type	Shielding type		Non-shielding type		
	0.2mm ²	0.3mm ²	0.2mm ²	0.3mm ²	
No. of pairs	2	5.9 (40)	6.3 (47)	5.3 (30)	5.7 (36)
	3	6.1 (46)	6.6 (60)	5.5 (35)	6.0 (44)
	4	6.5 (55)	7.0 (70)	5.9 (42)	6.4 (55)
	5	7.0 (65)	7.5 (80)	6.4 (50)	6.9 (65)
	6	7.4 (75)	8.0 (90)	6.8 (60)	7.4 (75)
	8	8.6 (95)	9.3 (120)	7.8 (75)	8.7 (100)
	10	9.2 (110)	10.0 (135)	8.6 (90)	9.4 (120)
	12	9.4 (120)	10.5 (150)	8.8 (100)	9.7 (135)
	16	10.5 (145)	11.5 (195)	9.7 (130)	11.0 (165)
	20	11.5 (180)	12.5 (230)	11.0 (155)	12.0 (210)

- Note 1 . Unit length : 100m , : Stock item
- 2 . Core identification : Page 6.
- 3 . Current carrying capacity : Page 8 see table 3.

Overall Dia. 【Multi core with and without shielding type】/(Approx. mass) unit : mm , (kg/km)

Type	Shielding type		Non-shielding type		
	0.2mm ²	0.3mm ²	0.2mm ²	0.3mm ²	
No. of cond.	2	4.6 (25)	4.8 (29)	4.0 (18)	4.2 (21)
	3	4.7 (28)	5.0 (33)	4.1 (21)	4.4 (25)
	4	5.0 (32)	5.3 (39)	4.4 (24)	4.7 (30)
	5	5.3 (37)	5.6 (44)	4.7 (28)	5.0 (35)
	6	5.5 (42)	5.9 (50)	4.9 (32)	5.3 (40)
	8	6.1 (55)	6.5 (65)	5.5 (40)	5.9 (55)
	10	6.4 (60)	6.9 (75)	5.8 (46)	6.3 (60)
	12	6.5 (65)	7.0 (80)	5.9 (55)	6.4 (70)
	16	7.1 (80)	7.6 (100)	6.5 (65)	7.0 (85)
	20	7.6 (95)	8.3 (120)	7.0 (80)	7.7 (105)

- Note 1 . Unit length : 100m
- 2 . Core identification : Page 6.
- 3 . Current carrying capacity : Page 8 see table 3.

“RBT 2-V” for flexure part

RBT 2-V(SB)

RBT 2-V

Rating : 60 , 600 V

Hitachi Specification : SP31-91134B for shielding type
 SP31-91114B for non-shielding type

Size variation

Conductor			Ins. dia. (mm)	Max. cond. resistance (/km)
Size (mm ²)	Stranding (No./mm)	Dia. (mm)		
0.5	7/14/0.08	1.0	1.8	42.3
0.75	7/21/0.08	1.3	2.1	28.2
1.25	7/36/0.08	1.7	2.5	16.4
2	7/57/0.08	2.1	2.9	10.4

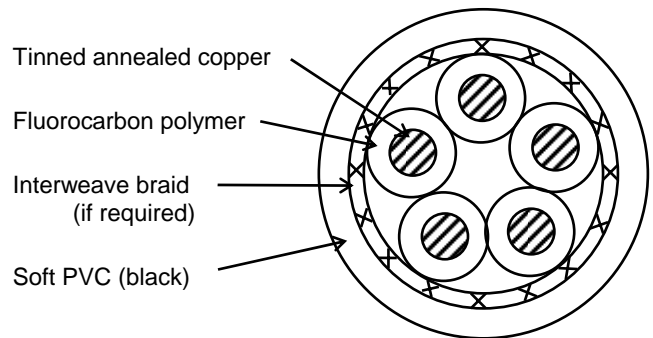

Overall Dia. 【Multi core with shielding type】/(Approx. mass)

unit : mm , (kg/km)

Size	0.5mm ²	0.75mm ²	1.25mm ²	2mm ²
No. of cond	2	6.5 (50)	6.9 (60)	7.7 (80)
	3	6.8 (60)	7.3 (75)	8.2 (100)
	4	7.3 (75)	7.9 (90)	9.0 (125)
	5	7.8 (85)	8.7 (110)	9.8 (145)
	6	8.6 (100)	9.3 (125)	10.5 (170)
	8	9.8 (130)	11.0 (160)	12.5 (225)
	10	10.5 (145)	11.5 (190)	13.5 (265)
	12	11.0 (165)	12.0 (210)	13.5 (300)
	16	12.0 (210)	13.0 (265)	15.5 (385)
	20	13.5 (250)	14.5 (325)	17.5 (485)

- Note 1 . Unit length : 100m , : Stock item
 2 . Core identification : Page 6.
 3 . Current carrying capacity : Page 8 see table 3.

Overall Dia. 【Multi core without shielding type】/(Approx. mass)

unit : mm , (kg/km)

Size	0.5mm ²	0.75mm ²	1.25mm ²	2mm ²
No. of cond.	2	5.9 (39)	6.3 (47)	7.1 (65)
	3	6.2 (47)	6.7 (60)	7.6 (85)
	4	6.7 (60)	7.3 (75)	8.2 (105)
	5	7.2 (70)	7.9 (90)	9.2 (130)
	6	7.8 (80)	8.7 (105)	9.9 (150)
	8	9.2 (110)	10.0 (140)	12.0 (200)
	10	9.8 (125)	11.0 (160)	12.5 (235)
	12	10.5 (145)	11.0 (185)	13.0 (270)
	16	11.5 (185)	12.5 (240)	14.5 (355)
	20	12.5 (225)	14.0 (295)	16.5 (435)

- Note 1 . Unit length : 100m
 2 . Core identification : Page 6.
 3 . Current carrying capacity : Page 8 see table 3.

“RBT 2-V” for flexure part

RBT 2-V(SB)

RBT 2-V

Rating : 60 , 600 V

Hitachi Specification : SP31-91133B for shielding type
 SP31-91113B for non-shielding type

Size variation

Size (mm ²)	Conductor		Ins. dia. (mm)	Max. cond. resistance (/km)
	Stranding (No./mm)	Dia. (mm)		
0.5	7/14/0.08	1.0	1.8	42.3
0.75	7/21/0.08	1.3	2.1	28.2
1.25	7/36/0.08	1.7	2.5	16.4

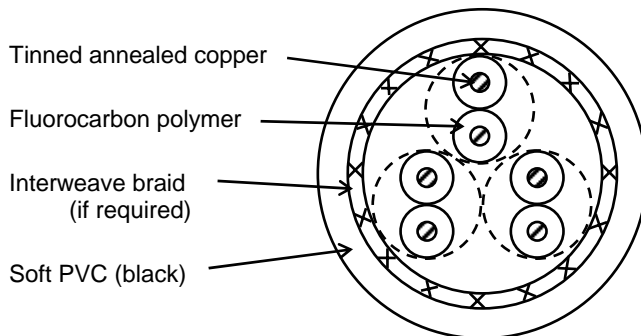

Overall Dia. 【Multi pair with shielding type】/(Approx. mass) unit : mm , (kg/km)

Size	0.5mm ²		0.75mm ²		1.25mm ²	
No. of pairs	2	9.3 (95)	10.5 (115)	12.0 (155)		
	3	9.8 (115)	11.0 (140)	12.5 (195)		
	4	11.0 (135)	12.0 (170)	13.5 (235)		
	5	12.0 (165)	13.0 (205)	15.0 (290)		
	6	13.0 (190)	14.5 (245)	16.5 (340)		
	8	15.0 (250)	16.5 (315)	19.5 (470)		
	10	16.5 (290)	18.0 (385)	21.0 (550)		
	12	17.0 (345)	19.0 (430)	22.0 (625)		
	16	19.0 (425)	21.0 (550)	25.0 (795)		
	20	21.0 (525)	24.0 (675)	27.0 (980)		

- Note 1 . Unit length : 100m
 2 . Core identification : Page 6.
 3 . Current carrying capacity : Page 8 see table 3.

Overall Dia. 【Multi pair without shielding type】/(Approx. mass) unit : mm , (kg/km)

Size	0.5mm ²		0.75mm ²		1.25mm ²	
No. of pairs	2	8.7 (75)	9.5 (95)	11.0 (130)		
	3	9.2 (95)	10.5 (115)	12.0 (170)		
	4	10.0 (115)	11.0 (145)	13.0 (210)		
	5	11.0 (135)	12.5 (180)	14.5 (260)		
	6	12.5 (165)	13.5 (210)	16.0 (305)		
	8	14.5 (220)	16.0 (280)	18.5 (410)		
	10	15.5 (260)	17.5 (340)	21.0 (495)		
	12	16.0 (290)	18.0 (385)	21.0 (565)		
	16	18.0 (375)	20.0 (495)	24.0 (730)		
	20	20.0 (470)	23.0 (615)	27.0 (910)		

- Note 1 . Unit length : 100m
 2 . Core identification : Page 6.
 3 . Current carrying capacity : Page 8 see table 3.

Core identification (Color code)

<< Multi pair Type >>

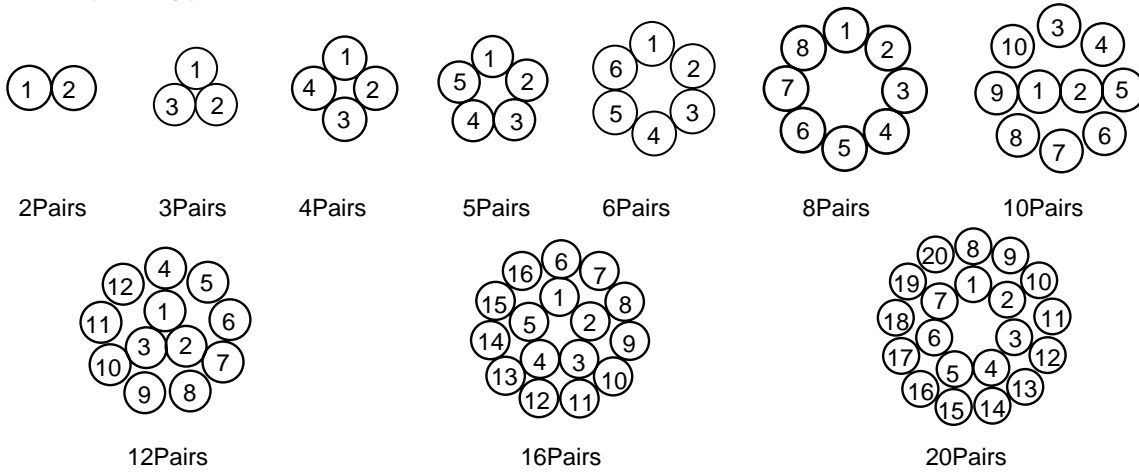
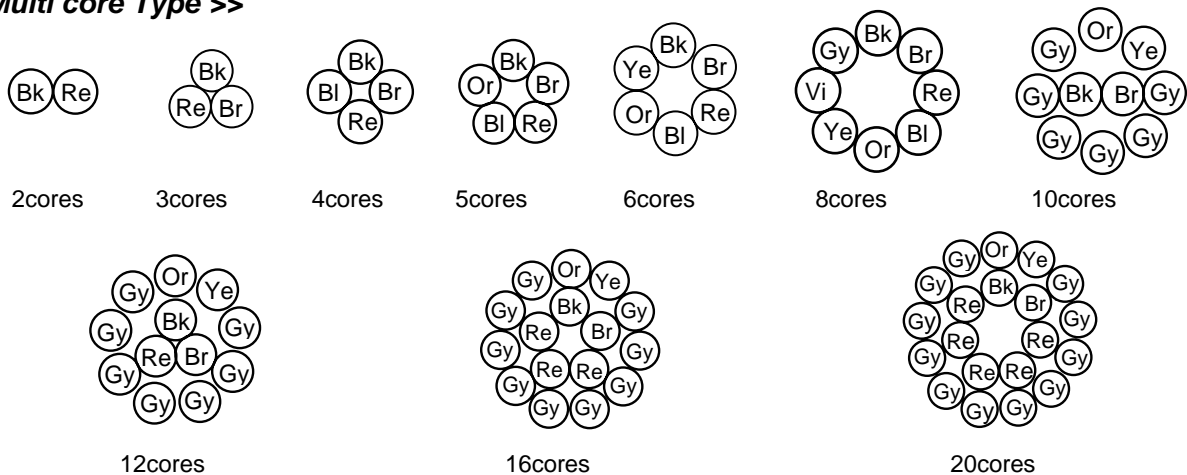

Table 1 Color code of multi pair type.

No. of pair	2 ~ 3pairs		4 ~ 6pairs		7 ~ 10pairs		11 ~ 15pairs		16 ~ 20pairs	
	1st.cond.	2nd.cond.	1st.cond.	2nd.cond.	1st.cond.	2nd.cond.	1st.cond.	2nd.cond.	1st.cond.	2nd.cond.
1	Black	Brown	Black	Brown	Black	Brown	Black	Brown	Black	Brown
2	Black	Red	Black	Red	Black	Red	Black	Red	Black	Red
3	Brown	Red	Black	Orange	Black	Orange	Black	Orange	Black	Orange
4			Brown	Red	Black	Yellow	Black	Yellow	Black	Yellow
5			Brown	Orange	Brown	Red	Black	Green	Black	Green
6			Red	Orange	Brown	Orange	Brown	Red	Black	Blue
7					Brown	Yellow	Brown	Orange	Brown	Red
8					Red	Orange	Brown	Yellow	Brown	Orange
9					Red	Yellow	Brown	Green	Brown	Yellow
10					Orange	Yellow	Red	Orange	Brown	Green
11							Red	Yellow	Brown	Blue
12							Red	Green	Red	Orange
13							Orange	Yellow	Red	Yellow
14							Orange	Green	Red	Green
15							Yellow	Green	Red	Blue
16									Orange	Yellow
17									Orange	Green
18									Orange	Blue
19									Yellow	Green
20									Yellow	Blue

<< Multi core Type >>



Note ; Bk:Black, Re:Red, Br:Brown, Bl:Blue, Or:Orange, Ye:Yellow, Vi:Violet, Gray:Gy.

Expectation of flex life

(1) Foreword

NASA has metal fatigue experiment formula which is relationship between bending radius and stress strain. We developed way to the expecting the flex life of cables by our bending test data and metal fatigue experiment formula of NASA.

(2) Expectation curve of flex(bending) life

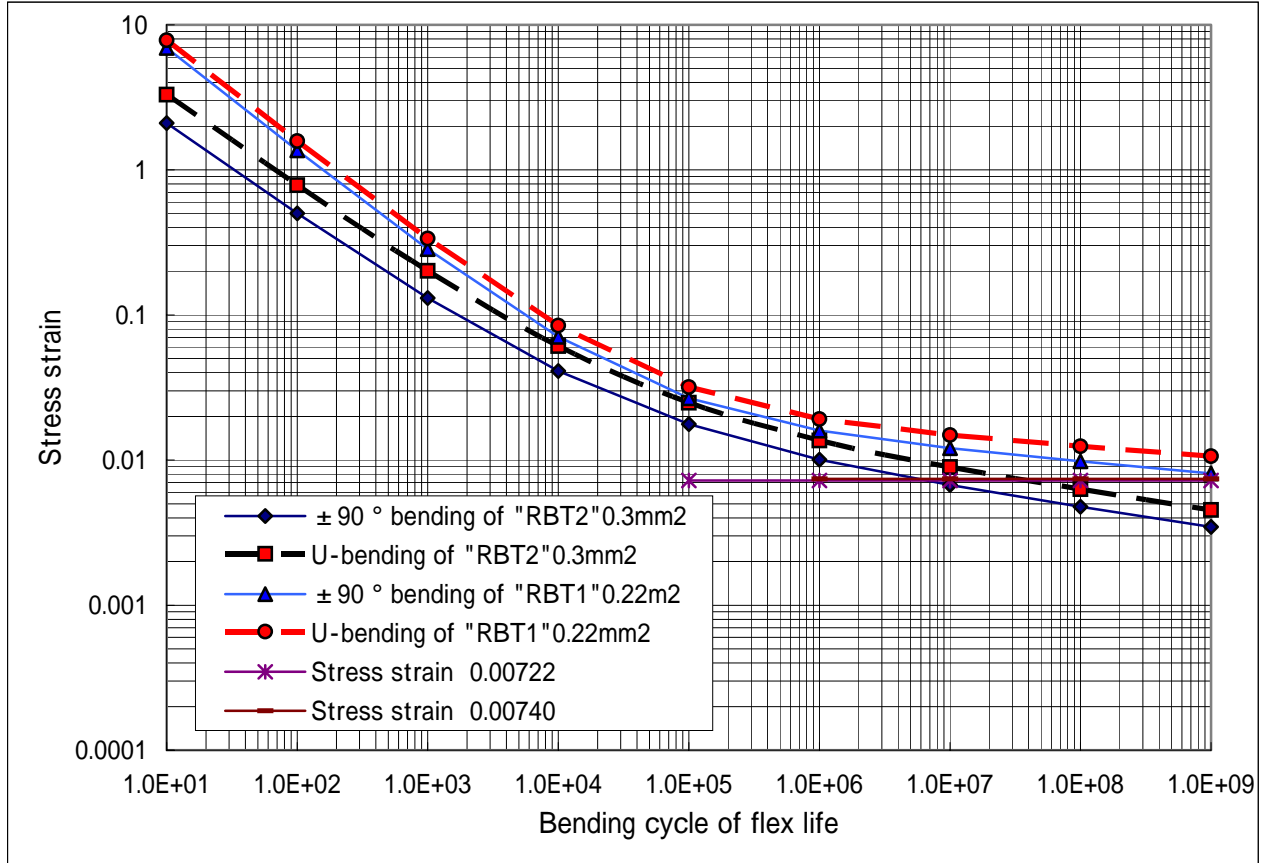

<<Formula>>

$$\text{Stress strain} = \frac{\frac{d}{2}}{R + t + \frac{D}{2}}$$

d: Conductor diameter
 R: Bending radius
 t: Sheath thickness + shielding thickness + bind tape thickness
 D: Insulation diameter

(3) Example

Following table is examples of 2 specimens.

Description	Bending radius*	Stress strain	Expected flex life	
			± 90 ° bending	U-bending
RBT 1-V(SB) 6P × 0.22mm ²	57mm	0.00740	> 1 × 10 ⁸	> 1 × 10 ⁸
RBT 2-V(SB) 6P × 0.3mm ²	48mm	0.00722	Approx. 6.5 × 10 ⁶	Approx. 3 × 10 ⁷

* Bending radius is 6 times of sheath diameter. (Our recommended condition)

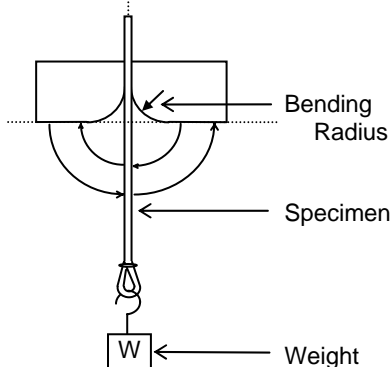

Fig.1 ±90°bending

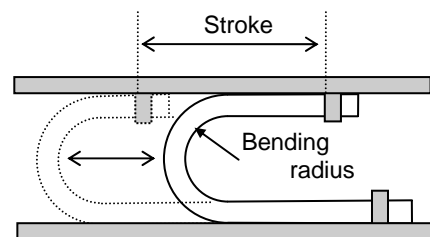

Fig.2 U-bending

Current carrying capacity

The current carrying capacities are given by following tables. The following data is conditioned on single cable wiring in free air at ambient temperature 40degree C.

Table 2 Current carrying capacity of "RBT 1-V" cable.

No. of pair	No. of core	Current carrying capacity [A]			
		0.14mm ²	0.22mm ²	0.32mm ²	0.56mm ²
1	2	4.2	5.5	5.6	7.0
-	3	3.5	4.5	4.6	5.9
2	4	3.1	4.0	4.1	5.3
-	5	2.9	3.7	3.7	5.0
3	6	2.7	3.4	3.5	4.7
4	8	2.5	3.1	3.1	4.4
5	10	2.1	2.7	2.8	3.6
6	12	2.0	2.6	2.6	3.4
8	16	1.8	2.3	2.4	3.1
10	20	1.7	2.1	2.2	2.9
12	-	1.5	2.0	2.0	2.6
16	-	1.3	1.7	1.7	2.3
20	-	1.2	1.5	1.6	2.0

Table 3 Current carrying capacity of "RBT 2-V" cable.

No. of pair	No. of core	Current carrying capacity [A]					
		0.2mm ²	0.3mm ²	0.5mm ²	0.75mm ²	1.25mm ²	2mm ²
1	2	5.4	6.9	10.0	12.7	17.5	23.4
-	3	4.5	5.7	8.4	10.7	14.7	19.8
2	4	4.0	5.1	7.5	9.6	13.1	17.0
-	5	3.7	4.7	7.0	8.9	12.4	16.5
3	6	3.5	4.4	6.6	8.5	11.7	15.7
4	8	3.2	4.1	6.1	7.8	10.8	14.5
5	10	2.7	3.4	5.1	6.5	8.8	11.5
6	12	2.6	3.3	4.9	6.2	8.4	11.0
8	16	2.3	3.0	4.4	5.6	7.6	9.9
10	20	2.2	2.7	4.0	5.1	7.0	9.1
12	-	2.0	2.5	3.7	4.7	6.4	-
16	-	1.7	2.2	3.2	4.1	5.6	-
20	-	1.5	1.9	2.9	3.7	5.0	-

Note;1

If many cables are bundled, current carrying capacity multiplied by adjustable factor;F as following table.

No. of bundled cables	1	2	3	4	5	6
Adjustable factor ; F	1.00	0.75	0.65	0.58	0.53	0.49

Note;2

If the ambient temperature is not 40degree C, current carrying capacity multiplied by adjustable factor;T as following table.

Ambient temperature()	25	30	35	40	45	50	55
Adjustable factor ; T	1.17	1.11	1.06	1.00	0.93	0.86	0.79